

INSTRUCTIONS FOR ORDERING PARTS

All service parts should be ordered through your authorized H&S dealer. He will be able to give you faster service if you will provide him with the following.

1. Model & Serial Number - Both can be located on the right side main frame of your unit.
2. All reference to left or right apply to the machine as viewed from the rear.
3. Parts should not be ordered from illustration only. Please order by complete part number.
4. If your dealer has to order parts - give shipping instructions.

VIA truck - large pieces (please specify local truck lines)

VIA United Parcel Service (include full address)

H&S MFG. CO. INC.	
MARSHFIELD, WIS.	
MOD. NO.	<input type="text"/>
SER. NO.	<input type="text"/>
DESCR.	<input type="text"/>

PLEASE RECORD NUMBERS FOR YOUR UNIT FOR QUICK REFERENCE

ABOUT IMPROVEMENTS

H&S IS CONTINUALLY STRIVING TO IMPROVE ITS' PRODUCTS.

We must therefore, reserve the right to make improvements or changes whenever it becomes practical to do so, without incurring any obligation to make changes or additions to the equipment previously sold.

DECAL LOCATION

Your H&S 6' & 9' Merger was manufactured with operator safety in mind. Located on the windrow merger are various decals to aid in operation, and warn of danger or caution areas. Pay close attention to all the decals on your Mini Merger.



DO NOT REMOVE ANY OF THESE DECALS. IF DECALS ARE LOST, DAMAGED, OR IF MINI MERGER IS REPAINTED, REPLACE DECALS. REMEMBER: DECALS ARE FOR YOUR PROTECTION AND SAFETY.

Listed below are the decals on your Mini Merger. These decals may be ordered individually by part number or by ordering a complete set.

ITEM	PART NO.	DESCRIPTION
A.	B12	(2) H&S Decal
B.		(2) Red Reflective
C.	1494K	(2) Warning - Do Not Remove Shields
D.	B6	(4) H&S Decal
E.	11599	(2) Warning - Do Not Go Near Leaks
F.	3398A	(3) Danger - Stay Clear
G.	3398C	(2) Danger - Shut Engine Off Completely
H.	71188B	Jack Storage Position
I.	73101	(2) Danger - Stay Clear of Moving Parts (W/Accelerator Only)
J.		Serial #
K.	3894	(2) Warning - Do Not Operate (W/Accelerator Only)
L.	1494B	(2) Warning - Do Not Remove (W/Accelerator Only)
M.	72203A	Warning - Help Avoid Injury
N.		Operator Manual Holder
O.		(2) Amber Reflective
	11601MM1	Complete Set of Decals
Paint - H&S Red		
	ZX21	Gallon
	ZX22	Quart
	ZX23	Pint

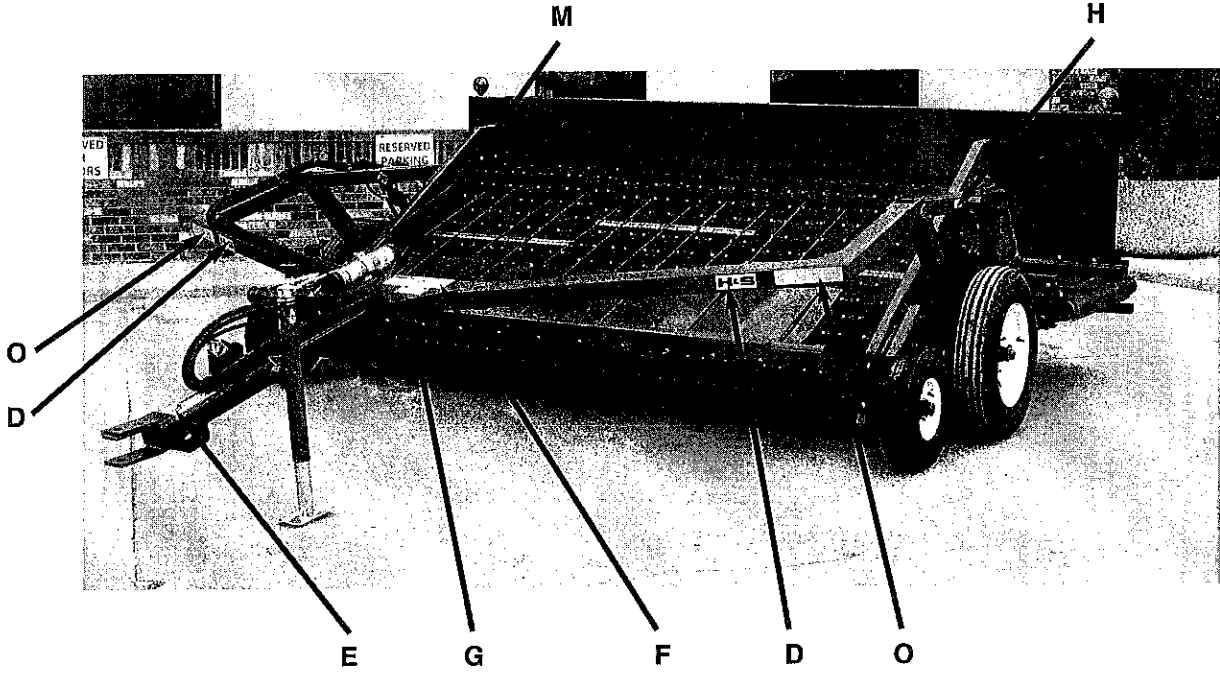

(Continued)

DECAL LOCATION (Continued)

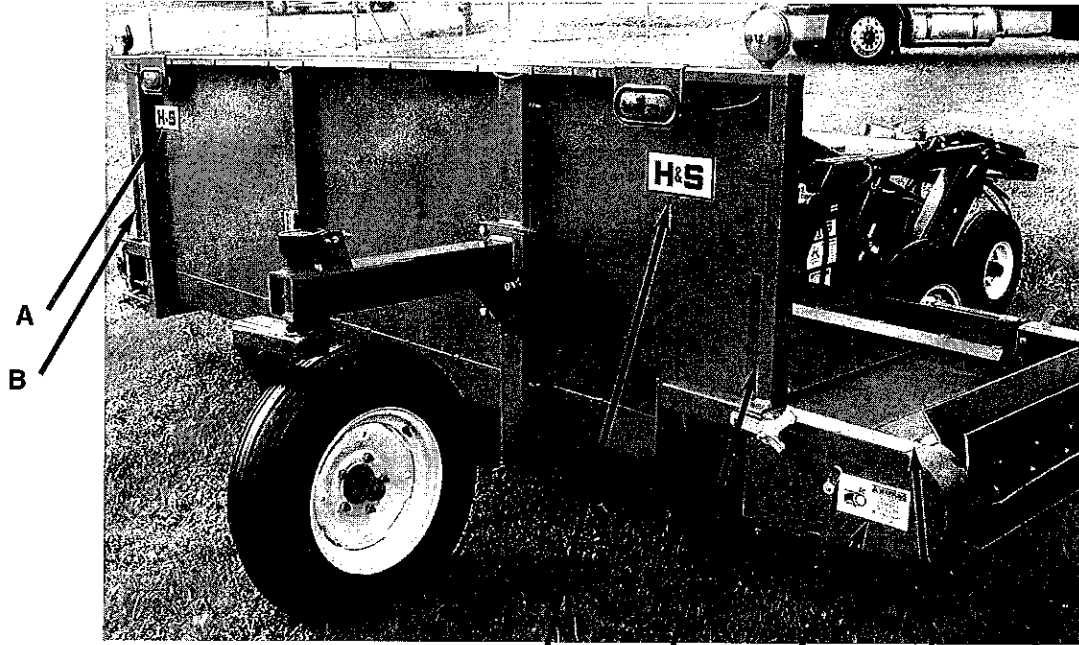

A
B
L
I
K
(Behind Shield)

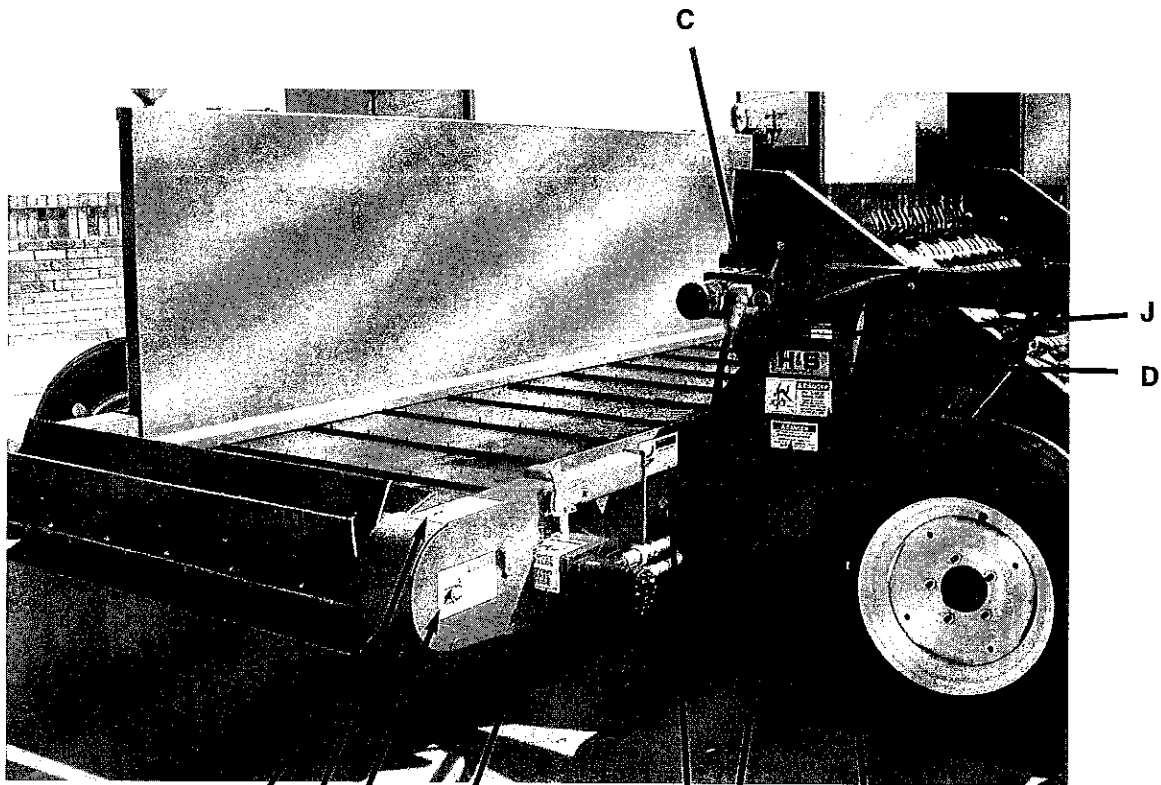

K
I
L
C
E
G
F
(Behind Shield)

FIGURE 1

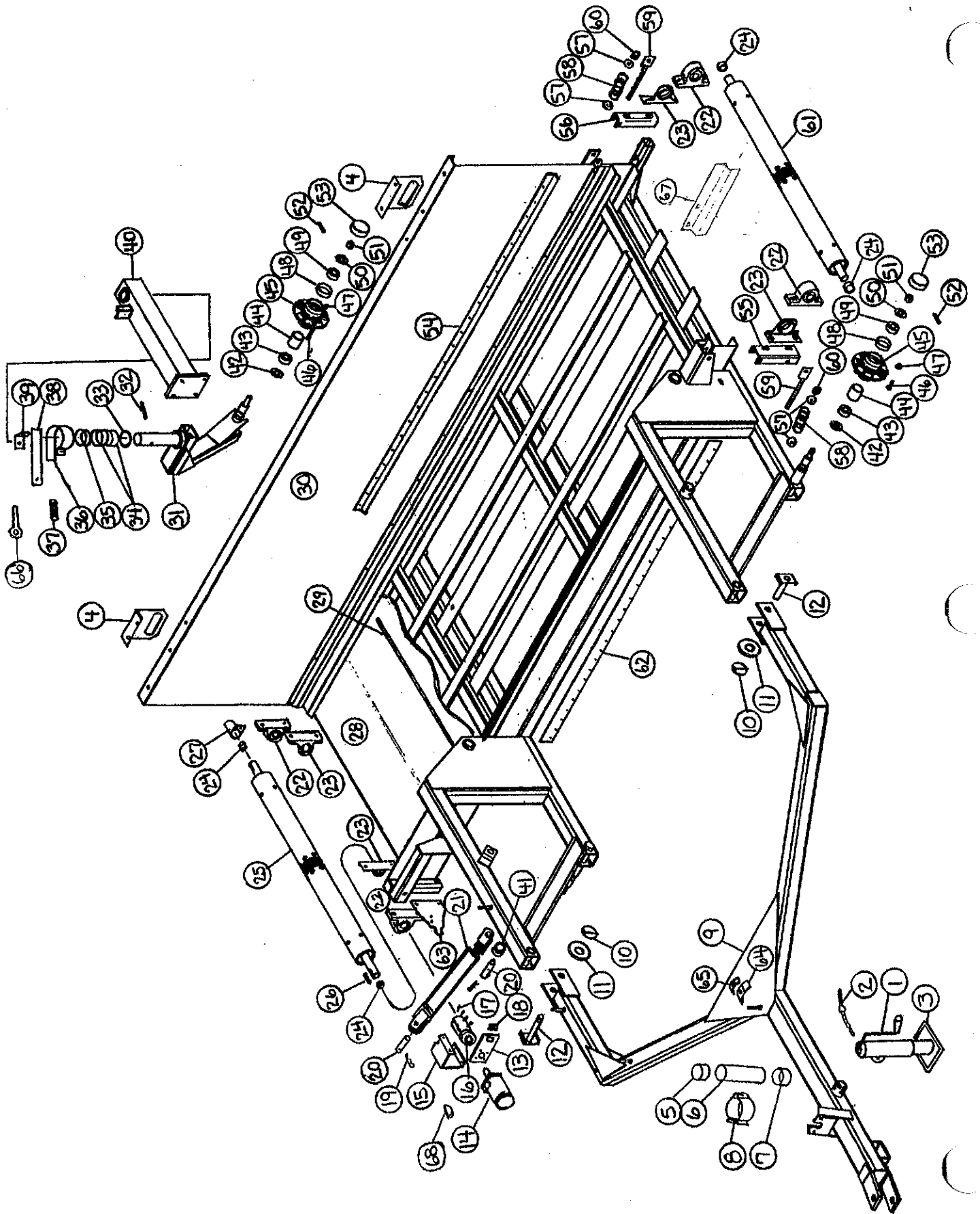

FIGURE 1
6' & 9' MERGER MAIN FRAME/POLE

ITEM	PART NO.		DESCRIPTION	ITEM	PART NO.		DESCRIPTION
	6' HEAD	9' HEAD			6' HEAD	9' HEAD	
1.	B17B	"	Jack Handle	36.	WM286	"	Brake Band
2.	BFR4	"	Jack Pin & Chain	37.	WM210	"	Spring-Red
3.	BFR223	"	Jack	38.	WM288	"	Brake Pad
4.	SWM28	"	Light Bracket	39.	WM211	"	Brake Angle
5.	S414	"	Cap	40.	SWM3	"	Caster Mount
6.	S415	"	Tube	41.	K132	"	Spacer
7.	S418	"	Cap W/Hole	42.	BFR57	"	Seal
8.	S416	"	Hanger Bracket	43.	BFR58	"	Inner Bearing
9.	SWM5	SWM65	Pole	44.	BFR59	"	Inner Race
10.	F56	"	Lynch Pin	45.	BFR60	"	Hub
11.	SWM36	"	Washer-Pivot	*	BFR67	"	Wheel 5 x 15 (3)
12.	SWM14	"	Pivot Pin	*	BFR128	"	Tire 6.70 x 15SL (3)
13.	DWM39	"	Torque Arm	46.	BFR143	"	Stud Bolt
14.	DF1	"	Hydraulic Motor	47.	BFR144	"	Nut
*	WM225	"	Seal Kit	48.	BFR61	"	Outer Race
15.	DWM42	"	Right Motor Shield	49.	BFR62	"	Outer Bearing
16.	DWM27	"	Coupler	50.	BFR63	"	Washer
17.	DWM137	"	Cap Screw-Coupler	51.	BFR64	"	Nut
18.	DWM45	"	Motor Spacer	52.	BFR65	"	Cotter Pin
19.	R70	"	Cotter Pins 3/16" x 2"	53.	BFR66	"	Hub Cap
20.	BFR517	"	Cylinder Pin	54.	SWM29	WM236	Skirt
21.	BFR69A	"	Cylinder	55.	SWM34	"	Tightener Arm
22.	DWM132	"	Pillow Block Bearing	56.	SWM33	"	Back Tightener Arm
23.	DWM36	"	Anti-Wrap Guard	57.	K68	"	Washer 1/2"
24.	SWM30	"	Head Spacer	58.	DWM125	"	Spring-Blue
25.	SWM11	"	Driver Roller	59.	DWM25	"	Tightener
26.	G23	"	Key 5/16" x 1-3/8"	60.	R29	"	Nut 1/2"
27.	DWM31	"	Shaft Shield	61.	SWM10	"	Conveyor Roller
28.	SWM19	WM237	Conveyor Belt	62.	SWM16	WM235	Skirt Belt
29.	SWM37	"	Lacing Pin	63.	DWM51	"	Male Torque Arm
*	SWM38	"	Cross Conveyor Lacing	64.	HE42	"	Hose Holder (6)
30.	SWM7	SWM66	Main Frame	65.	23N67	"	Hose Holder (4)
31.	SWM2	"	Caster	66.	WM287	"	I-Bolt
32.	BFR313	"	Roll Pin 5/16" x 2-3/4"	67.	SWM59	"	Skirt Extention
33.	RG24	"	Bronze Washer 2"ID x 3"OD x 1/8"	68.	5B10	"	Key 1/4" x 1" Woodruff
34.	BFR527	"	Bronze Bushing 2"ID x 2-1/4"OD x 2"				* (Means Not Shown)
35.	DWM59	"	Brake Bushing				" (Means Same As Previous)

FIGURE 2

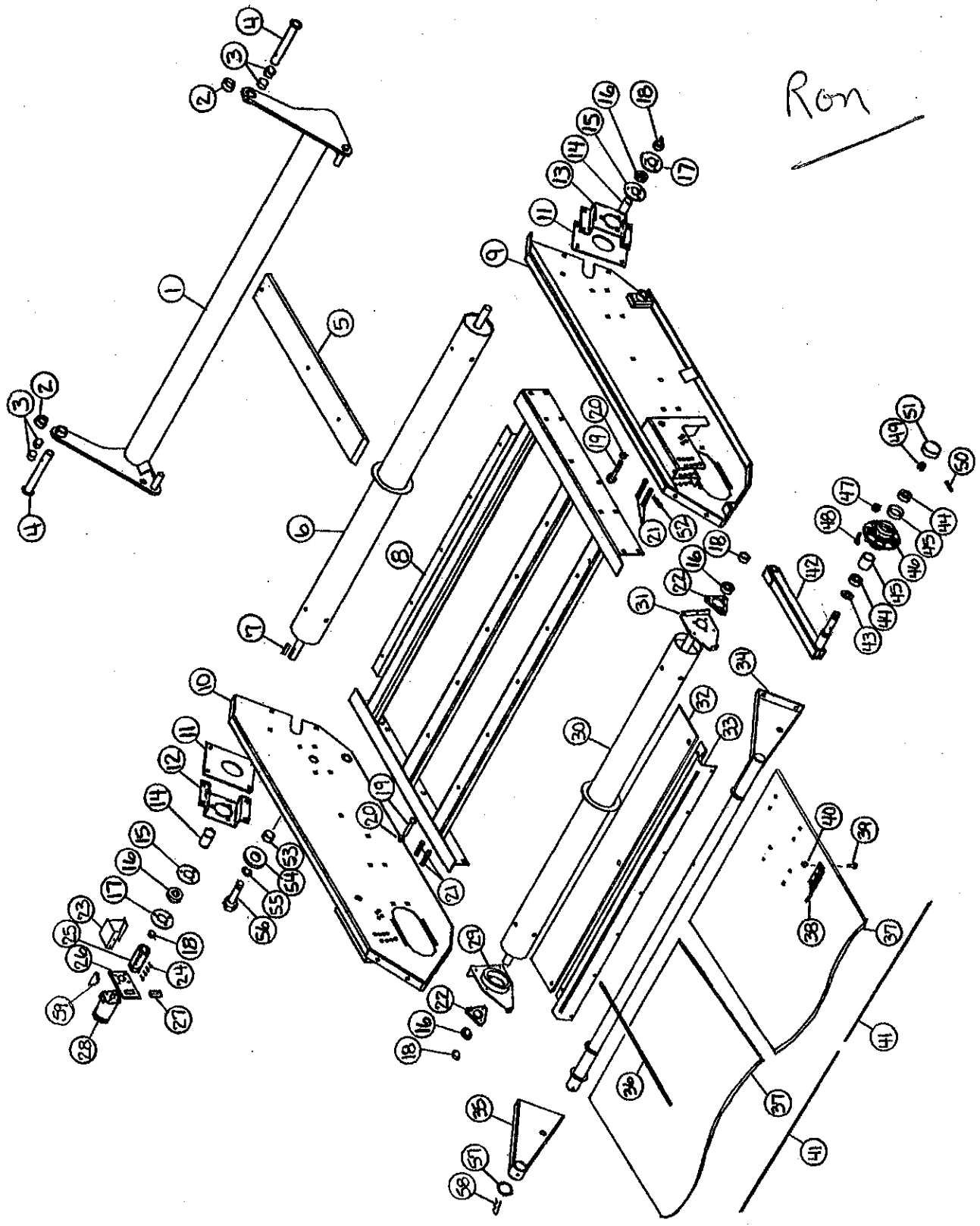
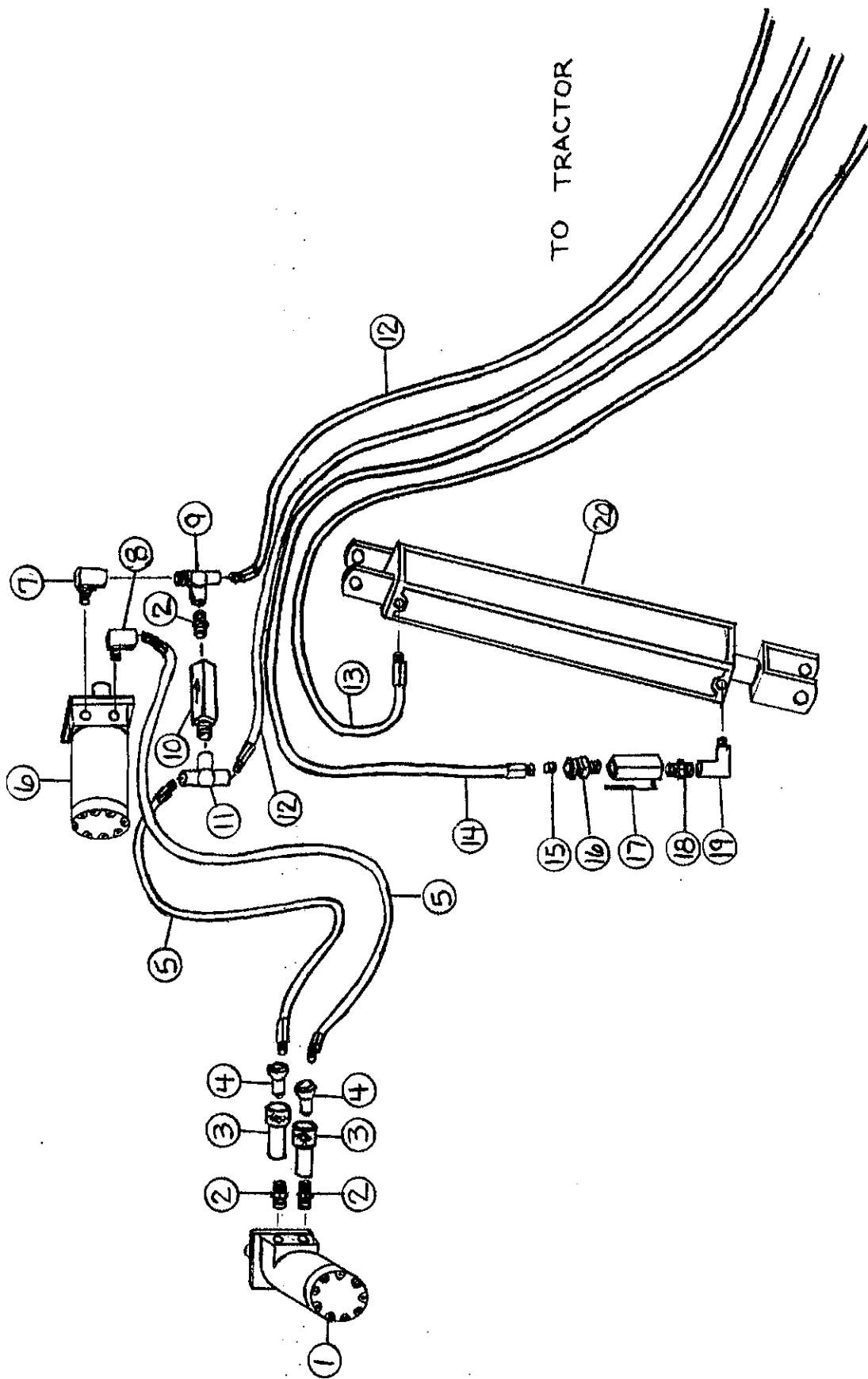

FIGURE 2 6' & 9' MERGER PICK-UP HEAD

ITEM	PART NO.		DESCRIPTION	ITEM	PART NO.		DESCRIPTION
	6' HEAD	9' HEAD			6' HEAD	9' HEAD	
1.	SWM12	WM230	Pickup Lifter	33.	SWM9	DWM2	Wind Guard Holder
2.	SWM30	"	Spacer	34.	SWM32	DWM228	Wind Guard
3.	RG132	"	Bushing 1-1/4" ID x 2" Long	35.	DWM226	"	Right Wind Guard
4.	SWM13	"	Pin	36.	WM60	"	Wind Guard Rods
5.	SWM15	"	Plastic Slides (5) 6' - (8) 9'	37.	SWM56	"	Pickup Belts Only (2) 6' - (3) 9'
6.	SWM77	WM341	Back Roller	*	SWM57	"	Pickup Belt Complete w/Teeth
7.	G23	"	Key 5/16" x 1-3/8"	*	SWM61	"	Repair Dutchman Kit
8.	SWM8	WM234	Pickup Belt Frame	*	SWM63	"	Repair Dutchman Kit 2003 & Newer
9.	DWM3	"	Left Panel	38.	SWM1	"	Pickup Teeth (260)
10.	DWM4	"	Right Panel	39.	SWM26	"	1/4" x 3/4" Elevator Bolts
11.	WM180	"	Side Panel Slot Plate	40.	SWM27	"	1/4" Keps Lock Nuts
12.	WM187	"	Bearing Bracket RH	41.	SWM41	"	Lacing Pin
13.	WM186	"	Bearing Bracket LH	*	SWM39	"	Alligator Lace
14.	WM343	"	PVC Spacer	42.	DWM229	"	Gauge Arms
15.	F145	"	Heavy Duty Flange	43.	CAT135A	"	Seal
16.	WM29	"	Bearing	44.	CAT10	"	Bearing (2)
17.	F143	"	Flange W/45 Deg. Zerk	45.	CAT9	"	Race (2)
18.	WM27	"	Lock Collar	46.	CAT177	"	Hub-Complete
19.	DWM7	"	Pivot Pin	47.	BFR144	"	Lug Nut
20.	R70	"	Cotter Pin 3/16" x 2"	48.	CAT128	"	Stud
21.	DWM127	"	Clevis Pin	49.	CAT12	"	Spindle Nut
22.	SWM40	"	3-Bolt Bearing Housing	50.	BFR65	"	Cotter Pin
*	SWM35	"	3-Bolt Bearing Complete	51.	CAT13	"	Hub Cap
23.	DWM43	"	Head Shield	*	SWM17	"	Wheel (2)
24.	DWM137	"	Cap Screw-Coupler	*	SWM18	"	Tire 5.70-8 (2)
25.	DWM27	"	Coupler	52.	ES7	"	Hair Pin
26.	DWM39	"	Hydraulic Motor Mount	53.	WM183	"	Pivot Bushing
27.	DWM45	"	Motor Spacer	54.	WM218	"	Washer
28.	WM177	"	Hydraulic Motor	55.	DWM171	"	1" Lock Washer
*	WM225	"	Seal Kit	56.	DWM177	"	Bolt 1" x 2-1/2" GR.5 Full Thd.
29.	WM179	"	Right Front Roller Bracket	57.	DWM227	"	Wind Guard Washer
* 30.	SWM76	WM342	Front Roller	58.	SWM55	"	Cotter Pin 1/4" x 2-1/2"
31.	WM192	"	Left Front Roller Bracket	59.	5B10	"	Key 1/4" x 1" Woodruff
32.	SWM31	DWM58	Poly Wind Guard	* (Means Not Shown) " (Means Same As Previous)			

*Belts
present*

FIGURE 3



**FIGURE 3
6' & 9' MERGER HYDRAULICS**

ITEM	PART NO.		DESCRIPTION
	6' HEAD	9' HEAD	
1.	DF1	"	Hyd. Motor-Cross Conveyor
*	WM225	"	Seal Kit
2.	WM141	"	1/2" Nipple Nut
3.	DWM206	"	Female Coupler
4.	DWM205	"	Male Coupler
5.	SWM23	"	Hose 1/2" x 42"
6.	WM177	DWM84	Hyd. Motor-Pickup
*	WM225	"	Seal Kit
7.	LW174	"	1/2" Male Adapter Union
8.	HE58	"	1/2" Street Elbow
9.	LW96	"	1/2" Street Tee
10.	DF18	"	1/2" Check Valve
11.	DF8	"	1/2" Tee
12.	SWM22	----	Hose 1/2" x 216"
	----	SWM67	Hose 1/2" x 240"
13.	SWM24	----	Hose 1/4" x 180"
	----	SWM68	Hose 1/4" x 204"
14.	SWM25	----	Hose 1/4" x 190"
	----	SWM69	Hose 1/4" x 214"
15.	DWM250	"	Orifice .042
16.	BFR122	"	3/8" Male Adapter Union
*	T244	"	Adapter Union & Orifice
17.	16SV338	"	3/8" Ball Valve
18.	BFR188	"	3/8" Nipple Nut
19.	23N234	"	3/8" Street Elbow
20.	BFR69A	"	2" x 8" Cylinder

* (Means Not Shown)

" (Means Same As Previous)

---- (Means Not Used On This Model)

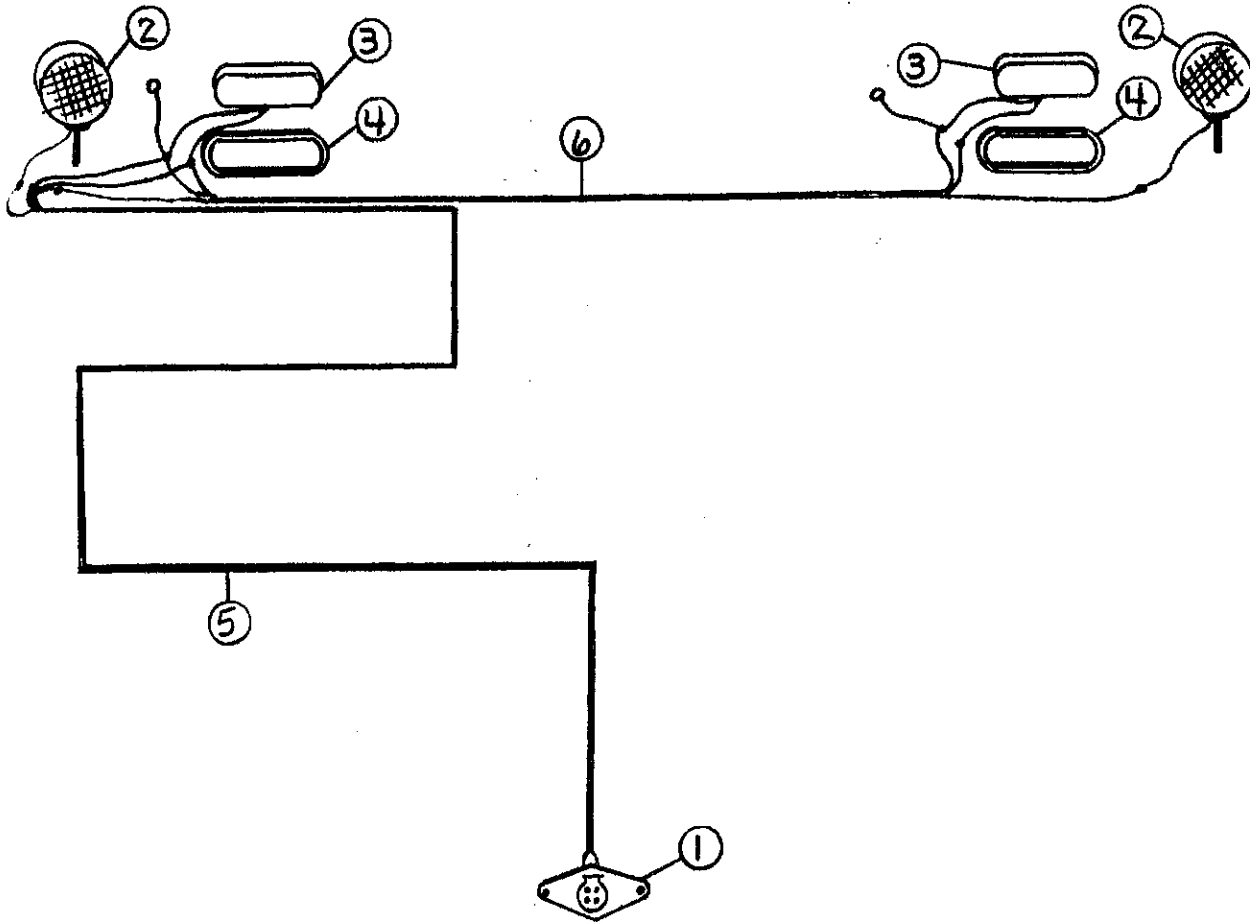

FIGURE 4
6' & 9' MERGER ELECTRICAL WIRING / LIGHTS

ITEM	PART NO.		DESCRIPTION
	6' HEAD	9'HEAD	
1.	SWM46	"	Plug In
2.	DWM129	"	Yellow Hazard Lights
3.	S310	"	Red Tail Lights
4.	S308	"	Rubber Light Mount
5.	SWM47	SWM70	Main Wire
6.	SWM48	SWM71	2nd Wire
7.	S317	"	Optional Tractor Cord

* (Means Not Shown)
 " (Means Same As Previous)

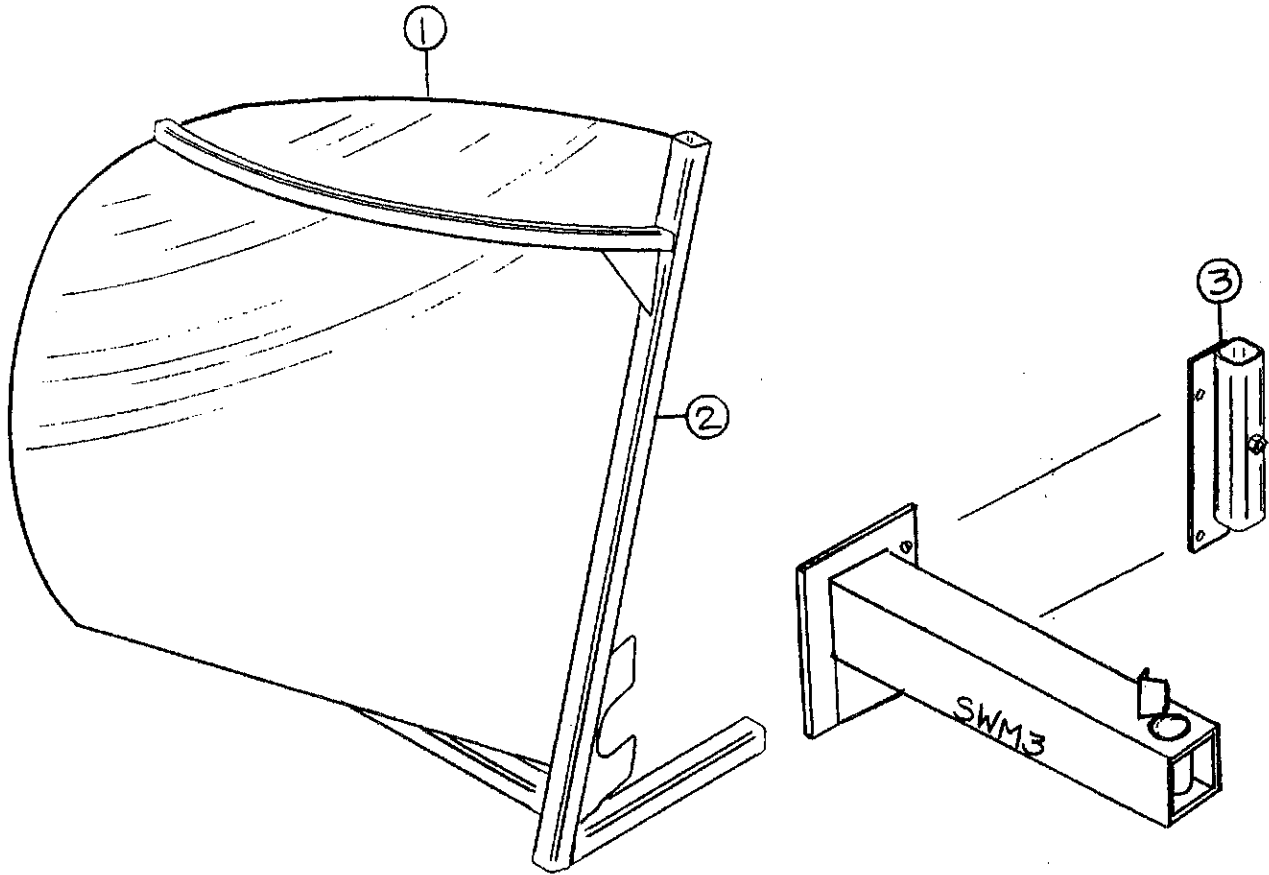

FIGURE 5
6' & 9' MERGER OPTIONAL WINDROW INVERTER

ITEM	PART NO.	DESCRIPTION
1.	SWM50	Windrow Inverter Poly
2.	SWM51	Windrow Inverter Frame
3.	SWM52	Storage Mount

(NOTE: Storage Mount Bolts onto SWM3 Caster Mount - See Fig. 1)

FIGURE 6

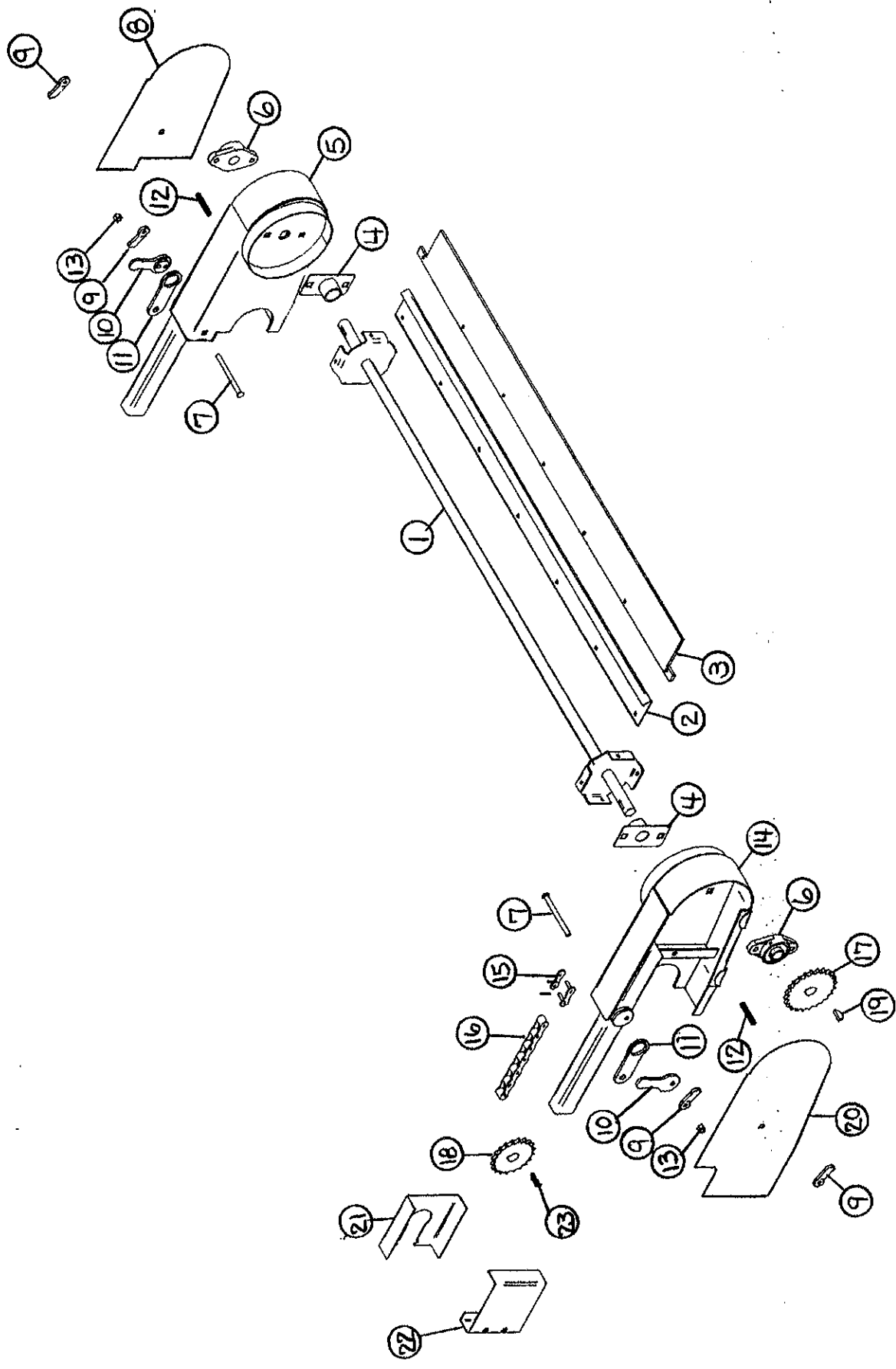

FIGURE 6
6' & 9' MERGER OPTIONAL ACCELERATOR

ITEM	PART NO.	DESCRIPTION
1.	SWM42	Accelerator Shaft
2.	SWM43	Accelerator Plate
3.	SWM44	Rubber
4.	DWM211	Wrap Guard
5.	DWM208	Mounting Bracket 1
6.	DWM221	1" Bearing
7.	DWM222	3/8" x 5-1/2" Carriage Bolt GR.5
8.	DWM214	Shield 1
9.	DWM219	Handle Nut
10.	DWM210	Latch Handle
11.	DWM217	Latch
12.	DWM218	Ready Rod
13.	A14	3/8" Nylock Nut
14.	DWM209	Mounting Bracket 2
15.	X61	#50 Connector Link
16.	SWM53	#50 Roller Chain 57 Pitch
17.	X106	Sprocket 24T 1" Bore
18.	SWM45	Sprocket 17T 1-1/4" Bore
19.	5B10	Woodruff Key 1/4" x 1"
20.	DWM213	Shield
21.	DWM216	Sprocket Shield Back
22.	DWM215	Sprocket Shield
23.	S135	1/4" x 1-1/4" Sq. Key
*	SWM58	Complete Accelerator Kit

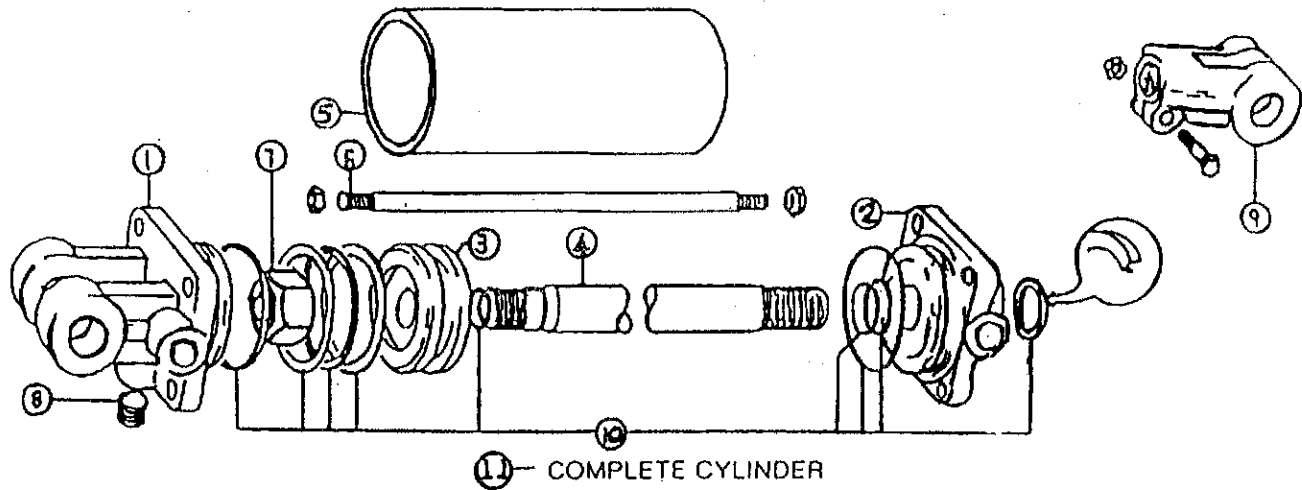

FIGURE 7
6' & 9' MERGER
HYDRAULIC CYLINDER 8"

ITEM	PART NO.	DESCRIPTION
1.	23N142A	Clevis Cap
2.	23N143A	Rod Cap
3.	23N144	Piston
4.	T134A	Rod
5.	BFR68	Cylinder Tube
6.	T186	Tie Rod
7.	23N148	Piston Nut
8.	23N149	Plug
9.	23N150A	Rod Clevis
10.	23N151	Seal Kit
11.	BFR69A	Complete Cylinder

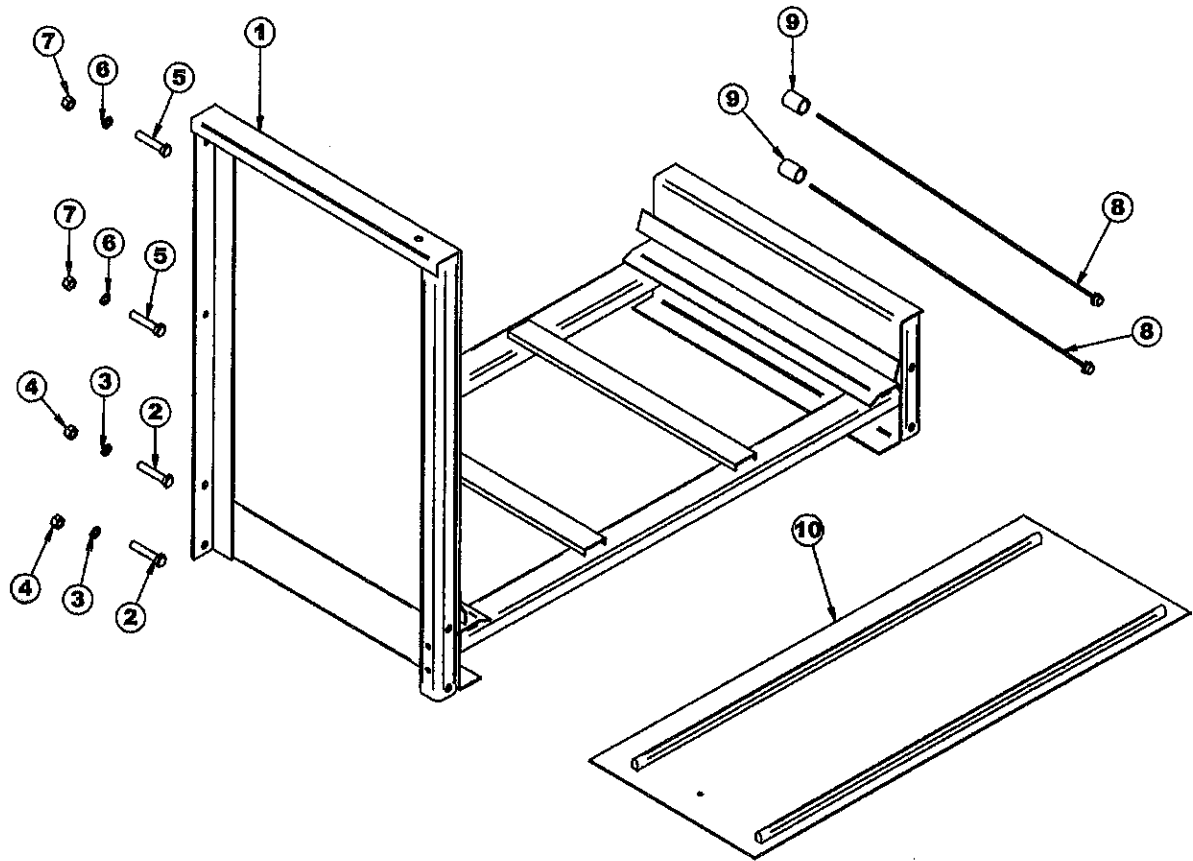

FIGURE 8
6' & 9' Merger 2' Extension

ITEM	PART NO.	DESCRIPTION
1.	SWM62	Extension
2.	WM328	1/2" x 2-3/4" Bolt Gr. 5
3.	R35	1/2" Lock Washer
4.	R29	1/2" Nut
5.	12N51	3/8" x 2-3/4" Bolt Gr. 5
6.	B68	3/8" Lock Washer
7.	K60	3/8" Nut
8.	16SV141	1/2" x 24" Hose (1/2"MP & 1/2"MPX)
9.	PB105	1/2" Pipe Coupler
10.	WM214	Belt Extension
*	WM220	Lacing Pin
*		30" - 16 Ga Wire

* (Means Not Shown)

- SERVICE NOTES -

Lined area for service notes.

887-6381